

I N S T R U C T I O N B O O K

F O R

M O D E L S 8 7 7 5 / 8 7 7 6

T E R M A L I N E [®] L O A D R E S I S T O R

BIRD
Electronic Corporation

30303 Aurora Road, Cleveland, Ohio 44139-2794

Copyright 1990 by Bird Electronic Corporation

LIMITED WARRANTY

All products manufactured by Seller are warranted to be free from defects in material and workmanship for a period of one (1) year, unless otherwise specified, from date of shipment and to conform to applicable specifications, drawings, blueprints and/or samples. Seller's sole obligation under these warranties shall be to issue credit, repair or replace any item or part thereof which is proved to be other than as warranted; no allowance shall be made for any labor charges of Buyer for replacement of parts, adjustment or repairs, or any other work, unless such charges are authorized in advance by Seller.

If Seller's products are claimed to be defective in material or workmanship or not to conform to specifications, drawings, blueprints and/or samples, Seller shall, upon prompt notice thereof, either examine the products where they are located or issue shipping instructions for return to Seller (transportation-charges prepaid by Buyer). In the event any of our products are proved to be other than as warranted, transportation costs (cheapest way) to and from Seller's plant, will be borne by Seller and reimbursement or credit will be made for amounts so expended by Buyer. Every such claim for breach of these warranties shall be deemed to be waived by Buyer unless made in writing within ten (10) days from the date of discovery of the defect.

The above warranties shall not extend to any products or parts thereof which have been subjected to any misuse or neglect, damaged by accident, rendered defective by reason of improper installation or by the performance of repairs or alterations outside of our plant, and shall not apply to any goods or parts thereof furnished by Buyer or acquired from others at Buyer's request and/or to Buyer's specifications. In addition, Seller's warranties do not extend to the failure of tubes, transistors, fuses and batteries, or to other equipment and parts manufactured by others except to the extent of the original manufacturer's warranty to Seller.

The obligations under the foregoing warranties are limited to the precise terms thereof. These warranties provide exclusive remedies, expressly in lieu of all other remedies including claims for special or consequential damages. SELLER NEITHER MAKES NOR ASSUMES ANY OTHER WARRANTY WHATSOEVER, WHETHER EXPRESS, STATUTORY, OR IMPLIED, INCLUDING WARRANTIES OF MERCHANTABILITY AND FITNESS, AND NO PERSON IS AUTHORIZED TO ASSUME FOR SELLER ANY OBLIGATION OR LIABILITY NOT STRICTLY IN ACCORDANCE WITH THE FOREGOING.

MODELS COVERED IN THIS INSTRUCTION BOOK

8775

8776

SAFETY PRECAUTIONS

The following are general safety precautions that are not necessarily related to any specific part or procedure and do not necessarily appear elsewhere in this publication.

Keep away from live circuits.

Operating personnel must at all times observe normal safety regulations. Do not attempt to replace parts or disconnect an RF transmission or any other high voltage line while power is applied. When working with high voltage always have someone present who is capable of rendering aid if necessary. Personnel working with or near high voltage should be familiar with modern methods of resuscitation.

Warning: Warning notes call attention to a procedure, which if not correctly performed could result in personal injury.

Caution: Caution notes call attention to a procedure, which if not correctly performed could result in damage to the instrument.

The following will appear in the text of this publication and are shown here for emphasis.

```
*****
*                               C A U T I O N                               *
*                               *                                           *
* The water flow must be kept in the right direction;                       *
* opposite flow will cause almost immediate burnout.                       *
*****
```

```
*****
*                               W A R N I N G                               *
*                               *                                           *
* When using dry cleaning solvents, provide adequate                       *
* ventilation and observe normal safety precautions.                       *
* Many dry cleaning agents emit toxic fumes that                         *
* could be harmful to your health if inhaled.                               *
*****
```

```
*****
*                               W A R N I N G                               *
*                               *                                           *
* The resistor used in this load consists of a resistive                   *
* film on a special substrate. If the substrate is                         *
* broken, there will probably be sharp pieces or                          *
* splinters inside the load housing. Caution should be                    *
* exercised to avoid possible injury.                                       *
*****
```

Continued

```

*****
*                                     C A U T I O N                                     *
*                                     *                                               *
* Do not apply more than rated RF power to the load.  The *
* water flow rate and inlet temp. (5°C to 60°C) must be *
* as specified; viz., *
*                                     Gal/Min      Gal/Min *
*          kW   Models   at 5°C      at 60°C *
*          50   (8755/6)   9 (34 lpm)  11 (41.6 lpm) *
* In effect, adequate and uninterrupted full water flow *
* is more critical than temperature. *
*****

```

```

*****
*                                     C A U T I O N                                     *
*                                     *                                               *
* Be sure cooling liquid is flowing through the load *
* before RF power is applied and make sure the cooling *
* liquid supply is not interrupted while load is in *
* operation.  Even momentary interruption of coolant *
* supply while load power is applied will cause almost *
* immediate burnout. *
*****

```

```

*****
*                                     C A U T I O N                                     *
*                                     *                                               *
* Never reverse the cooling water connections.  It is *
* very important for the safety of the load resistor to *
* observe proper flow direction.  Also, when the load is *
* first installed or is reconnected, run the water for *
* approximately a minute to fill the system and remove *
* all bubbles before turning on the RF power. *
*****

```

```

*****
*                                     C A U T I O N                                     *
*                                     *                                               *
* Do not disconnect water flow switch leads from control *
* assembly.  Any operation of the load without proper *
* functioning of cooling system will cause almost *
* immediate destruction of the resistor element. *
*****

```

TABLE OF CONTENTS

	<u>Page</u>
SAFETY PRECAUTIONS	i
INTRODUCTION	
General.....	v
Purpose and Function.....	v
Control System Option.....	v
Use as a Wattmeter.....	v
SECTION I - INSTALLATION	
General.....	1
Load Resistor Connections.....	1
Water Line Attachment.....	2
Cooling Water Quality.....	2
Flow Switch.....	2
Control Box.....	2
Pre-Operational Checkout.....	3
SECTION II - THEORY OF OPERATION	
General.....	4
Heat Transfer.....	4
Cooling Water for Model 8775/76.....	4
Flow Interlock Control Circuit.....	5
SECTION III - OPERATION	
General.....	6
Operating as a Load Resistor.....	6
Operating as an RF Wattmeter.....	7
Shutdown Procedure.....	7
SECTION IV - MAINTENANCE	
General.....	8
Cleaning.....	8
RF Load Resistor.....	8
Replacement Procedure for Resistive Element.....	8
Replacement Procedure for Fractured Resistors.....	10
Front Connector Assembly.....	11
Water Flow Switch.....	12
Time Delay Switch.....	12
Pilot Light.....	13

TABLE OF CONTENTS [CONT.]

	<u>Page</u>
SECTION V - REPLACEMENT PARTS LIST	
General.....	16
TABLES	
Specifications.....	vi
ILLUSTRATIONS	
Resistor Removal.....	14
RF Input Connector, Exploded View.....	15

MODELS 8775/76 TERMALINE® LOAD RESISTOR

INTRODUCTION

GENERAL

The 8775/76 Series Load Resistor is designed as a compact, low-reflection and nonradiating termination for RF transmission lines. Cooled by internal water flow, it generates almost no ambient heat, making installation space minimal and convenient. It dissipates up to 50 kW continuous power as used with 50 ohm coaxial transmission lines.

PURPOSE AND FUNCTION

The Series is designed for use with certain connector types of 3-1/8 inch coaxial lines. See Specifications for individual models. They maintain a VSWR of less than 1.1 from 1000 Hz up to 900 MHz. This Series is intended for use on CW, AM, FM, SSB, and TV modulation envelopes, and within certain limitations on radar or pulse modes. Information on applications involving pulse-type signals should be obtained directly from Bird Electronic Corporation.

CONTROL SYSTEM OPTION

The Series 8775/76 equipment consists basically of the load resistor unit. An accessory protective control system is available as optional equipment. When duly installed, this system protects the load by shutting off RF power when water flow is too low or interrupted. Discussions of the Flow Control (Installation and Maintenance Sections) herein should be ignored when not applicable. These models have the feature of field replacement of the resistor element, described in the Maintenance Section, paragraphs 4-8 and 4-9.

USE AS A WATTMETER

When used in conjunction with a Bird Model 460 or a Model 4805 Type THRULINE® Wattmeter, these load resistors may be used for direct reading power measurements up to 50 kW.

SPECIFICATIONS FOR MODELS 8775/76 TERMALINE® LOAD RESISTOR

Impedance.....	50 ohms
VSWR	
1000 Hz-900 MHz.....	1.1:1.0 maximum
Connectors	
Model 8775.....	3-1/8" EIA Flanged
Model 8776.....	3-1/8" Unflanged Flush Center Conductor
Power Rating.....	50,000W
Frequency Range.....	1 kHz-900 MHz
Modes.....	CW, AM, FM, SSB, TV, and certain pulse types
Dimensions.....	19-1/2"L (495.3 mm) 3-1/2" Housing Dia. (88.9 mm)
Model 8775.....	5-3/16" Max Dia. (131.8 mm)
Model 8776.....	5" Max Dia. (127.0 mm)
Input Water Temperature Range.....	5°C to 60°C (41F to 140F)
Water Flow - Minimum Rate.....	9 GPM at 5°C - 11 GPM at 60°C
Water Connections.....	3/4" Standard hose thread
Weight	
Model 8775.....	15 lb 13 oz. (7.2 kg)
Model 8776.....	15 lb 5 oz. (7.0 kg)
AC Power Requirements, With Optional Items Only.....	115/230 V, 50/60 Hz
Housing Material.....	Aluminum alloy and brass
Operating Position.....	Any

SECTION I - INSTALLATION

1-1. GENERAL

1-2. The compact design of the load enables it to be installed in very confined spaces. It requires no ventilation and may be placed at any attitude. Do not install where subject to severe vibration or to physical shock. The load is ready for connection as received from the factory. It is useful to check the 50 ohm input resistance of the load before attachment, (see paragraph 4-6). Clean all conductors and insulator surfaces on transmission line face if required and check RF input connector. Use an aerosol type contact cleaner or any good dry cleaning solvent on a cloth for this purpose.

1-3. LOAD RESISTOR CONNECTIONS

1-4. Attach the load resistor to the RF line, but do not tighten. Use connector kits for respective models as follows:

- a. Model 8775, 3-1/8 inch EIA, swivel flange, 50 ohms.
 1. Use 3-1/8 inch EIA coupling kit, P/N 4600-020, which includes: six each 3/8-16 x 1-1/2 inch bolt and nut sets, O-Ring, and insulated center bullet.
 2. Insert the center bullet, push it in to seat the insulator in the facing, and install O-Ring in groove if required.
 3. Connect the coaxial input in a straight line, push carefully on the center contact to close. The swivel flange on the load makes connection independent of a fixed flange on the coaxial input.
 4. Insert bolt sets and tighten the nuts evenly all around.
- b. Model 8776, 3-1/8 inch unflanged, 50 ohms, flush center conductor.
 1. Use coupling kit, P/N 5-726 or RCA MI-27791K-4A, which includes: outer sleeve with two clamping bands and the center conductor coupling bullet.
 2. Insert the center bullet and bottom it on the midpoint nibs.
 3. Position the outer sleeve, with clamping bands over input connector.
 4. Introduce the transmission line and seat it snugly against the coupling stops.
 5. Position the clamp bands evenly about 1-3/4 inches apart and tighten.

1-5. Rotate the load so that warning label shows and the outlet water tube is placed to best advantage. Tighten RF connection, securing the clamps or bolt sets firmly and evenly.

1-6. Do not disturb the socket head cap screws joining the connector section to the main housing.

1-7. WATER LINE ATTACHMENT

* C A U T I O N *
* *
* The water flow must be kept in the right direction; *
* opposite flow will cause almost immediate burnout. *

1-8. The RF load comes supplied with standard 3/4 inch hose fittings. The water INLET (at the back on center) and water OUTLET (adjacent, at 90° to INLET) mate with 3/4 inch water hose connectors. The water flow switch is installed on the water inlet line (see paragraph 1-11 below). For rigid piping connections, replace both the water INLET and OUTLET hose adapters (Bird P/N 5-065-2) with 1/2 inch male pipe or pipe fittings.

1-9. COOLING WATER QUALITY

1-10. Water quality is important. Refer to paragraph 2-7 for explanation and description. In general, any potable water is satisfactory. This would include: purified, filtered city supply or soft water (demineralized).

1-11. FLOW SWITCH

1-12. The ports of the flow switch are 3/4 inch NPT Female. The direction of flow is marked on the casting of the flow tube and on the operating head - observe carefully; opposite connection will restrict water flow and cause load failure. The flow switch may be connected to the inlet or the outlet pipe of the load, but be certain the flow through the switch is in the correct direction. Connect the 1/2 inch NPT nipple and 1/2 inch to 3/4 inch bushing part numbers 5-489-1 and 5-490-1. Or connect by hose or pipe, with the flow switch not over 20 feet from load. Attach hose to switch with a 3/4 inch hose nipple part number 5-903. Do not connect flow switch leads at this time. Turn on water and check system for leaks and operation.

1-13. CONTROL BOX

1-14. The wiring center and remaining elements of the control system are contained in the control box. This includes the terminal strip and three BX cable clamps for the input connections, a pilot lamp and the delay timer. Only wiring material is needed. The unit operates on 115 V or 230 V ac, part number 8750-101-1 or 8750-101-2. The pilot lamp on top of the box is a "safe operation" signal; it lights only when ac power is on and adequate water supply is flowing. After the pilot goes on, a timer delay of approximately 12 seconds allows time for water flow to stabilize before closing transmitter interlock.

1-15. The control box is mounted through four 1/4 inch holes on a 5 x 5 inch square in the back. Position it for best view of the pilot light and easy attachment of the BX cable and wiring. Connect leads for both voltages as depicted on the wiring schematic inside your control box. Note - These connections are critical - wire carefully, as follows:

- a. Water flow switch leads to terminals 3 and 5.
- b. Interlock switch leads to 6 and 7.
- c. AC power to 2 and 3 for 115 V and 230 V operation.

1-16. PRE-OPERATIONAL CHECKOUT

1-17. BEFORE ATTEMPTING TO OPERATE THE RF LOAD either under test or actual operating conditions, TEST the complete water system and INTERLOCK CONTROL as follows:

- a. Make sure ac and transmitter interlock power are OFF.
- b. Connect an ohmmeter across terminals 6 and 7 (Interlock).
- c. Turn ac power on.
- d. Turn water supply on and note when water flow switch operates (audible click).
- e. In approximately 12 seconds, the ohmmeter reading on 6 and 7 should drop, indicating operation of the time delay switch.
- f. Water flow from the WATER OUTLET connection of the load must be not less than 9 gallons per minute at 5°C (41F) increasing to 11 gallons per minutes at 60°C (140F) for respective models in table of Section III.

1-18. As a precautionary measure, the pre-operational checkout should be performed each time the load is to be put into service.

SECTION II - THEORY OF OPERATION

2-1. GENERAL

2-2. This TERMALINE® Coaxial Load Resistor is unique in that it employs primarily external water cooling of the resistor element. By using this technique, the need for an intermediate dielectric fluid to transfer the heat generated in the resistor element has been eliminated, reducing the physical size of the load to a virtual minimum. This simplified system allows use of the loads in more varied environments, and attachment at any position.

2-3. HEAT TRANSFER

2-4. The 50 ohm resistor consists of a ceramic substrate with a deposited resistive film. The heat generated by absorption of RF power is transferred from the heated film to the water flowing over it through a restricted chamber surrounding the resistor body. This water, first conducted to the front of the load resistor, passes over the entire length of the resistor and is discharged through the sealed water chamber at the rear of the load. The dielectric characteristics and distinctive design of these enclosures provide a very accurate 50 ohm termination over the specified frequency range of this load - 1000 Hz to 900 MHz.

2-5. The absence of intermediate cooling fluids considerably simplifies the construction and sealing of this unit. It can be readily disassembled in the field for resistor element replacement (see Section IV - Maintenance).

2-6. Because there is practically no heat transfer to the outer housing of the load, the housing remains at a cool ambient temperature even under full power conditions. Virtually all of the power input to the load is transformed into heat which is carried away by the cooling water. Therefore, the differential in output and input temperatures of the water times the amount of flow constitutes a very accurate gauge of the power consumed by the load. The amount of this power dissipation may be calculated from the following formula:

$$P = 0.263 (T_1 - T_2) \text{ GPM.}$$

Where: P = Power in kilowatts
T₁ = Outlet water temperature in °C
T₂ = Inlet water temperature in °C
GPM = Water flow in gallons per minute

In °F the formula is: $P = 0.146 (T_1 - T_2) \text{ GPM}$

2-7. COOLING WATER FOR MODEL 8775/76

2-8. The electrical performance of these RF loads is affected by impurities or other chemical additives in the water. The presence of salts in the water definitely makes the device unusable as it causes rapid increase in VSWR. Therefore, sea water or silty water should not be used for cooling the loads.

2-9. The thermal performance of this series of loads is affected by impurities, particularly those impurities that accumulate in the form of scale on the exposed surfaces of the water-conducting members of the load assembly. This may result in an increase in the thermal and/or fluid resistance/s of the load and in turn cause the load to overheat and fail.

2-10. The following types of water are considered safe for the cooling of the 8775/76 loads: purified, filtered city, or soft water (demineralized). In general, any potable water is suitable for cooling the load. If the load is to be used in a closed system, e.g. water pump and heat exchanger, it is advised that only distilled water be used. Do not use deionized water.

2-11. FLOW INTERLOCK CONTROL CIRCUIT

2-12. The interlock control circuit provides instantaneous fail-safe protection of the transmitter and load in the event of even momentary interruption of the cooling water supply. This protection is necessary because dissipation of the heat generated by the RF power absorption is critically dependent upon a required minimum water flow regardless of inlet water temperature.

2-13. The water flow switch, attached to the water inlet of the load, is factory calibrated to open the electrical contacts whenever water flow drops below nine gallons per minute and to close when water flow exceeds this rate. When the water flow switch contacts open, the time delay relay switch is deactivated, which in turn opens the interlock switch causing immediate shutdown of the transmitter or other signal source. The time delay switch also keeps the interlock switch open for an interval of 12 \pm 2 seconds after the minimum flow of nine gallons per minutes has been re-established. This safeguarding feature assures proper operation of the cooling system before RF power can be applied to the load, preventing damage or burnout of the resistor element.

2-14. The control assembly also includes a large, torpedo-lens pilot light set on top of the box. As normally mounted, this red pilot lamp should be freely visible from nearly all front angles in the operating vicinity of the load unit/control assembly. After proper installation, described in Section I, lighting of this pilot lamp will serve as visible indication that the RF load is ready to receive power, or of trouble in the cooling supply (control) if it is not lighted.

SECTION III - OPERATION

3-1. GENERAL

3-2. The TERMALINE® RF Load is not equipped with any operating controls; therefore, the presence of an operator is not required while in use. Proper operation of the equipment is assured if the instructions contained in Section I - Installation are followed exactly.

```
*****
*                               C A U T I O N                               *
*                               *                                           *
* Do not apply more than rated RF power to the load. The *
* water flow rate and inlet temp. (5°C to 60°C) must be *
* as specified; viz., *
*                               Gal/Min      Gal/Min *
*          kW  Models  at 5°C      at 60°C *
*          50  (8755/6)  9 (34 lpm)  11 (41.6 lpm) *
* In effect, adequate and uninterrupted full water flow *
* is more critical than temperature. *
*****
```

```
*****
*                               C A U T I O N                               *
*                               *                                           *
* Be sure cooling liquid is flowing through the load *
* before RF power is applied and make sure the cooling *
* liquid supply is not interrupted while load is in *
* operation. Even momentary interruption of coolant *
* supply while load power is applied will cause almost *
* immediate burnout. *
*****
```

```
*****
*                               C A U T I O N                               *
*                               *                                           *
* Never reverse the cooling water connections. It is *
* very important for the safety of the load resistor to *
* observe proper flow direction. Also, when the load is *
* first installed or is reconnected, run the water for *
* approximately a minute to fill the system and remove *
* all bubbles before turning on the RF power. *
*****
```

3-3. OPERATING AS A LOAD RESISTOR

- a. Turn on ac power.
- b. Turn on water supply.
- c. Turn on interlock supply.
- d. Check that all coaxial power line connections are properly tightened.

e. Apply RF power to load. Proceed according to instructions pertaining to the specific transmitting equipment.

3-4. OPERATING AS AN RF WATTMETER

3-5. The RF load can be combined with a Bird rigid line series THRULINE® Wattmeter to form a absorption-type wattmeter by inserting the wattmeter line section just ahead of the RF load. Installation and operation of the wattmeter is covered in the THRULINE® Wattmeter Instruction Book. Note: Select a wattmeter model that is appropriate for the input connector of the load resistor - consult the Bird catalog.

- a. Proceed with operating function the same as in paragraph 3-3.
- b. Rotate the element in the line section to monitor incident or reflected power. Measurement is taken in the direction indicated by ARROW on element.

3-6. SHUTDOWN PROCEDURE

- a. Turn off RF power to load.
- b. Wait at least one minute.
- c. Turn off interlock ac power.
- d. Turn off water supply - always do this last.

```
*****
*                               C A U T I O N                               *
*                               *                                           *
* Do not disconnect water flow switch leads from control *
* assembly. Any operation of the load without proper *
* functioning of cooling system will cause almost *
* immediate destruction of the resistor element. *
*****
```

SECTION IV - MAINTENANCE

4-1. GENERAL

4-2. The TERMALINE® Coaxial Load Resistor is rugged and simple, requiring only nominal and routine attention. The load is designed to operate for long periods of time if care is taken not to exceed its power handling capabilities. Always handle the load with care to prevent subjecting it to unnecessary shock or impact.

4-3. CLEANING

```
*****  
*                               W A R N I N G                               *  
*                               *                                           *  
* When using dry cleaning solvents, provide adequate                       *  
* ventilation and observe normal safety precautions.                       *  
* Many dry cleaning agents emit toxic fumes that may be                 *  
* harmful to your health if inhaled.                                       *  
*****
```

4-4. The outside surface of the unit should be wiped free of dust and dirt at regular intervals. Disconnect the instrument from the transmission line and clean the RF input connector, both metallic and insulator surfaces. Use an aerosol type contact cleaner or any dry cleaning solvent on a cloth for this purpose.

4-5. RF LOAD RESISTOR

4-6. Accurate measurement of the dc resistance between the inner and outer conductors of the RF input connector will provide a good check of the condition of the load resistor. For this measurement, a resistance bridge or ohmmeter with an accuracy of 1 percent or better at 50 ohms should be used. Use low resistance leads, preferably a short piece of 50 ohm cable. The measured resistance should not deviate more than 2 ohms from the value stamped on the manila tag attached to the load. It is recommended that this resistance check be performed each time the load is to be used.

4-7. REPLACEMENT PROCEDURE FOR RESISTIVE ELEMENT

4-8. This series of water cooled loads is designed to be quickly and easily repaired in the field. If in performing the dc resistance check described previously in paragraph 4-6, a significant change in resistance is noted, or if for any reason the resistive element should fail, inexpensive replacement resistors are available. They can be installed in the load using the following procedures:

a. Resistor Removal - Note - Part numbers designated by brackets [] in text following are so indicated on figures 4-1 and 4-2.

1. If the load is not already removed from the system, disconnect the water hoses at the hose fittings [5] on load and disconnect unit from the RF transmission line.

2. Set the load on end with the water connections up, and using a 3/16 hex socket wrench, unscrew the six 1/4-20 x 2-1/2 inch socket head cap screws [6] holding the water chamber [3] to the main load housing. When all screws are loose, pull the water chamber assembly (with screws) straight off. It may be necessary to rock the chamber gently while carefully pulling it off.

3. The inner flow tube [9] will usually come out with the water chamber assembly, being held to it by the compression of the inner O-Ring [4] (water input) seal. This is normal, and if the resistor body is unbroken, there will be no need to remove the inner flow tube from water chamber assembly. The ground cap assembly [10] is fitted tightly within the water chamber and should normally remain with it. If the inner flow tube has stayed in the resistor section, simply grasp the resistor stop sleeve [7] on the flow tube and pull out the assembly. Note: This includes the cushioning O-Ring [8] which fits loosely below the stops sleeve - always take care not to lose it if it falls off. Also, if the brass stop sleeve [7] is removed at all, notice that it has a small escape hole at the side and an access counterbore leading to it. In reassembly, be sure this counterbore is facing toward the O-Ring and the resistor [1]. This is essential for internal water venting. Note - At reassembly, the water outlet holes and also the small shoulder at the base of the inner flow tube must fit into a mating recess in the input fitting at the bottom.

4. If the resistor [1] is intact it may be easily pulled straight out of the load housing, and is ready for replacement. The outer flow tube is captive, and will not come out of the housing at this stage.

b. Inspection - At this point, if the resistor has been successfully removed, inspect it carefully to ensure that it is not fractured. In the majority of cases, even in the event of resistor failure, the resistor substrate will remain intact. Next, examine the inside of the load housing assembly for any apparent damage to the internal parts. If no damage has been found, continue with resistor replacement step C-1, following. If however, the resistor is broken, other internal parts appear to be damaged, or if they do not fit together properly, proceed to paragraph 4-9, Replacement Procedure for Fractured Resistors.

c. Resistor Replacement -

1. Examine the inside of the load housing assembly for any apparent damage to the internal parts.

2. Insert new resistor [1] into the load housing until it reaches its fitting. Push in the resistor until it bottoms snugly. If resistor seems to be loose, refer to the procedure for the replacement of fractured resistors for instructions on how to tighten the resistor fitting.

3. Place the inner flow tube [9] inside the resistor and lower it until it reaches the resistor fitting. Gently work and twist the inner flow tube until it seats in the bottom of the input resistor fitting. This operation may also be done if the inner flow tube is still in position in the water chamber.

4. Make sure that the O-Ring [8] cushion is placed on the inner flow tube next to the resistor and the backup resistor sleeve [7] is right behind it. Watch orientation of sleeve (see step 4-8,a-3). There is no need to disturb the resistor cap assembly [10] in the water chamber for this procedure.

5. Replace the water chamber [3], gently rocking and twisting the chamber to achieve the proper flat seat on the outer housing. Note - If the water chamber [3] does not seem to fit properly, refer back to step 4-8,a-3 to see that the inner flow tube is properly in place.

6. Tighten the six 1/4-20 x 2-1/2 inch socket head cap screws [6]. Check the dc resistance between the inner and outer conductors - it should be approximately 50 ohms per paragraph 4-5. Then connect the load to a water source and check for leaks. If none appear, the load is ready for service.

4-9. REPLACEMENT PROCEDURE FOR FRACTURED RESISTORS

```
*****  
*                               W A R N I N G                               *  
*                               *                                           *  
* The resistor used in this load consists of a resistive *  
* film on a special substrate. If the substrate is *  
* broken, there will probably be sharp pieces or *  
* splinters inside the load housing. Caution should be *  
* exercised to avoid possible injury. *  
*****
```

a. Resistor Removal -

1. The load should already be disassembled to the point of step 4, paragraph 4-7a, preceding. Now turn the load on end, with the RF input connector up to allow any loose pieces of resistor to fall out of the load housing.

2. Using a 3/16 Allen wrench, loosen and remove the six 1/4-20 x 1-1/2 inch socket head cap screws [16] from the flanged end of the load housing, as shown in figure 4-2. The outer conductor assembly [12] or [14] may now be easily removed.

3. Remove the input center conductor assembly [11] or [13], figure 4-2, by pulling it out of the load housing, then carefully remove any remaining pieces of the resistor. Normally at this disassembly, the outer flow tube will remain with the load housing. Restore it to this position after inspection and

cleaning if it should come out. Inspect the inside of the load housing for any apparent damage.

4. Also, if it is in place in the water chamber, pull out the inner flow tube. Inspect carefully for broken pieces. Then grasp the projecting hub of the resistor cap assembly [10] firmly with your fingers and pull straight off with a strong even force.

5. Thoroughly wash all the inside portions of the three assemblies under clear running water; i.e., input section, load housing, and water chamber. Replace the resistor cap assembly in the water chamber at this time - push in firmly to bottom.

b. Resistor Replacement -

1. Insert replacement resistor [1] into the resistor fitting of the input center conductor assembly to test its tightness. The resistor should not have to be forced into the fitting, but it should be quite snug.

2. If the resistor is loose in the fitting, press the slotted finger contacts of the fitting together slightly and try the resistor again. Continue closing the ends of the resistor fitting until a snug fit is obtained. Then bottom the resistor in the fitting.

3. With the resistor still in place in the resistor fitting, insert the resistor and the input center conductor assembly into the load housing, as illustrated in figure 4-2, reversing the procedure in paragraph 4-9, step a-3, above. Then reinstall the outer conductor assembly and the six 1/4-20 x 1-1/2 inch socket head cap screws and tighten.

4. Stand the load on end with the RF input connector down, place the inner flow tube inside the resistor, and lower it until it reaches the resistor fitting. Gently move and twist the inner flow tube until it seats in the bottom of the resistor fitting.

5. Continue same procedure as given in paragraph 4-7, steps c4 through 6.

4-10. FRONT CONNECTOR ASSEMBLY

4-11. This portion of the load unit consists of the inner conductor [11] or [13] and the outer conductor [12] or [14], respectively. They may be released by removing the six screws [16] at the front of the housing flange, as described in paragraph 4-9, step a2 above. When the inner conductor has been pulled out, the O-Ring [15] seal, outer water flow tube seal may be readily changed, if desired. Do not attempt further disassembly of this part. Return to the factory for repair, if necessary; consult the company. Note - Procurement and use of the accessory protective control system, containing the water flow switch and control box, is optional.

Consider the replaceable parts described in paragraphs 4-12, 4-14, and 4-16 only when applicable.

4-12. WATER FLOW SWITCH

4-13. The water flow switch should be checked, and cleaned of any accumulated dirt or scale that might impede free movement of the control gate in the switch. This should be done after several months use, or if indicated. This component is not repairable; if found defective it must be replaced. For replacement proceed as follows:

- a. Make certain RF power, 115/230 Vac, and transmitter interlock supply are turned off.
- b. Disconnect leads at the water flow switch.
- c. Remove defective switch and replace with new unit.
- d. Connect flow switch leads.
- e. Perform preoperational checkout, paragraph 1-16.

4-14. TIME DELAY SWITCH

4-15. The relay cartridge (P/N 5-1664 for 115 Vac or 5-655 for 230 Vac) in the control box cannot be disassembled or repaired in the field. A faulty unit should simply be replaced as follows:

- a. Be sure RF power, 115/230 Vac, and transmitter interlock supply are off.
- b. Open the door of the control box by turning the slotted screw-head one quarter turn in either direction.
- c. Loosen the 8-32 pan head screw at the top of the relay clamp (8630-193), then press legs in slightly to release the retaining prongs of clamp.
- d. Pull the delay relay cartridge straight out of socket.
- e. To replace the relay, reverse procedure above. The socket is an ordinary octal type. When inserting the relay, rotate the cartridge carefully for alignment of the center post nub in the socket.
- f. Prongs of the clamp match the side slots in the socket holder. Fit the clamp in the slots and turn the head screw up snugly.
- g. Reverse procedures in 4-15a. and b. above.
- h. Perform pre-operational checkout, paragraph 1-16.

4-16. PILOT LIGHT

4-17. The pilot light lamp (P/N 5-970-1 for 115 Vac, or 5-970-2 for 230 Vac operation), may be reached simply by unscrewing the light indicator lens, (P/N 8750-106) on the topside of the control box. The lamp is a two-contact bayonet type. It is easily removed by pushing down gently, and slightly twisting counterclockwise. Reverse to replace. A list of replaceable parts is included in Section V.

FIGURE 4-1. RESISTOR REMOVAL

1/4-20 x 2-1/2 SOCKET HD
CAP SCREW (6 REQ'D.)

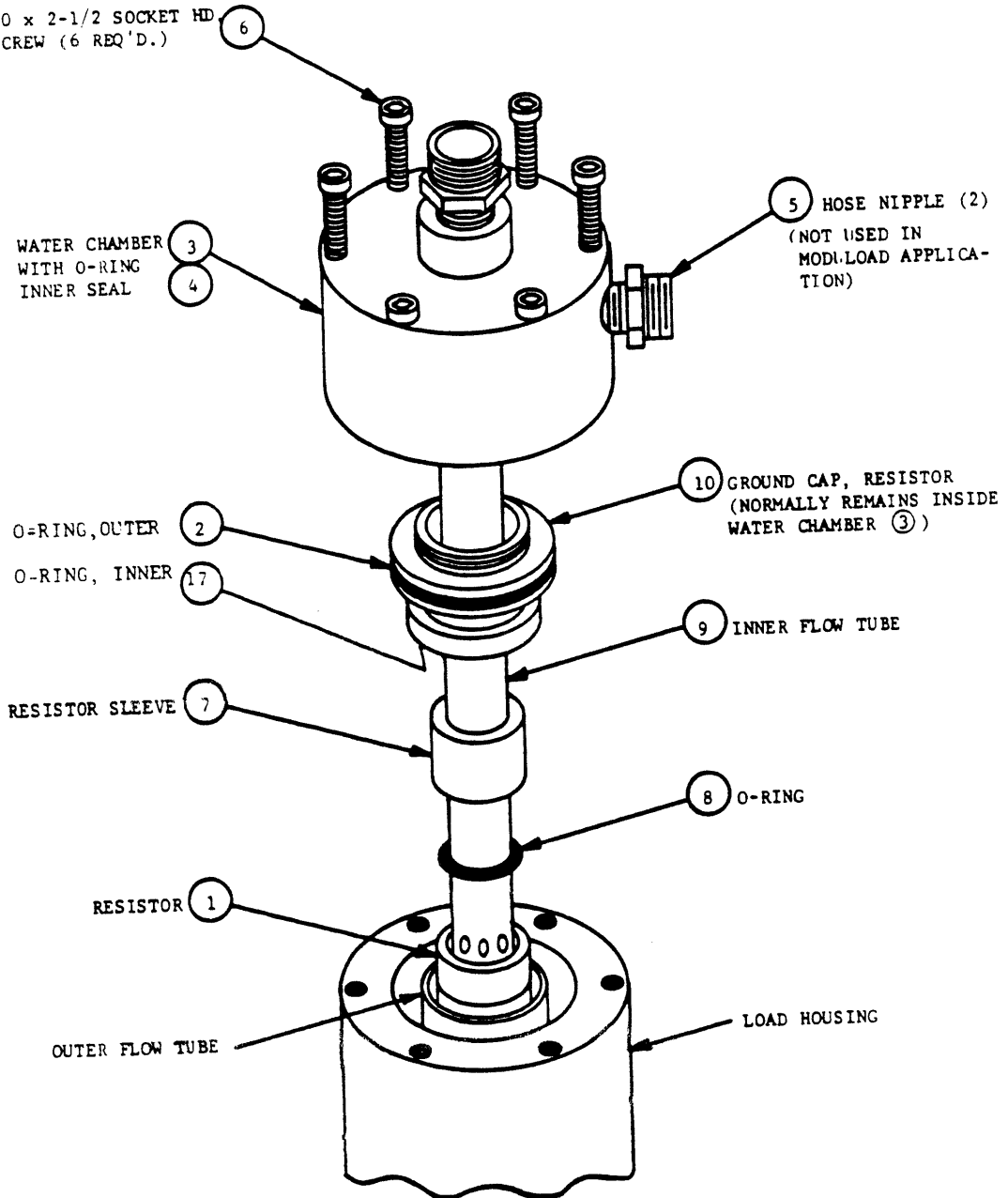
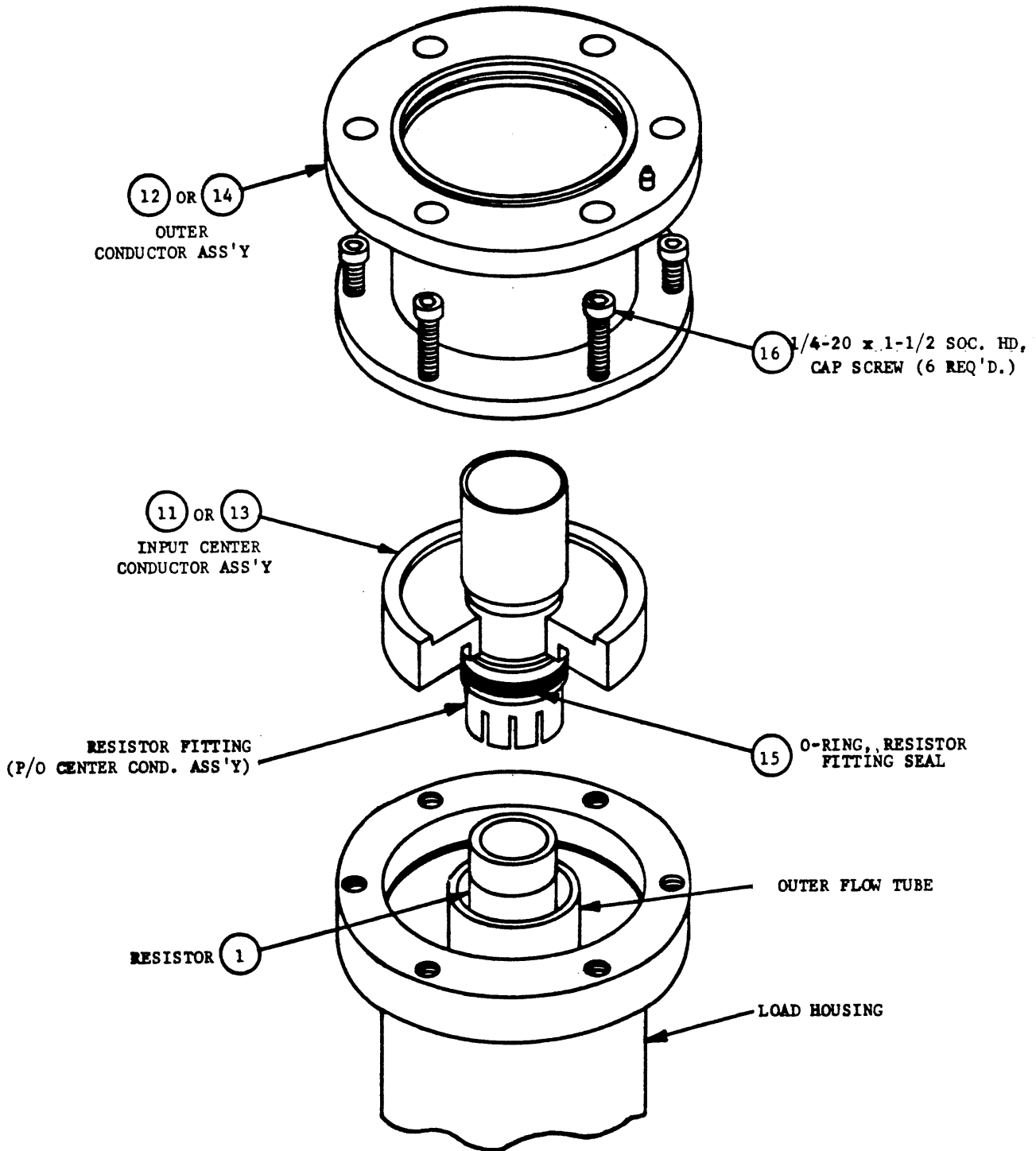

FIGURE 4-2. CONNECTOR REMOVAL



SECTION V - REPLACEMENT PARTS LIST

5-1. MODELS 8775/76

ITEM	QUANTITY	DESCRIPTION	PART NUMBER
1	1	Resistor	8755-027 or 029
2	1	Outer resistor cap seal O-Ring	8410-009
3	1	Water chamber	8755-014
4	1	Inlet seal O-Ring	5-099
5	2	Hose nipple	5-065-2
6	6	1/4-20 x 2-1/2" stainless steel socket head cap screws	Standard
7	1	Resistor sleeve	8755-026
8	1	Sleeve backup O-Ring	8110-059
9	1	Inner flow tube	8755-025
10	1	Outer flow tube	8755-024
11	1	Resistor ground cap assembly	8755-005

Front Connector Parts Assigned Per Model Type:

Model 8775 - 3-1/8" EIA Connector 50 ohms

11	1	Center conductor input assembly	8755-007
12	1	Outer conductor assembly	8755-004

Model 8776 - 3-1/8" Unflanged connector flush center conductor 50 ohms

13	1	Center conductor input assembly	8756-003
14	1	Outer conductor assembly	8756-002

For Both Models

15	1	Center conductor assembly O-Ring	5-1127
16	6	1/4-20 x 1-1/2" Stainless steel socket head cap screws (not shown)	Standard

17	1	Inner resistor cap seal O-Ring	5-567
----	---	--------------------------------	-------

Optional Equipment

18	1	Water flow switch	5-898-7
19	1	Control assembly	
		115 Vac	8750-101-1
		230 Vac	8750-101-2
20	1	Relay retaining clamp	8630-193
21	1	Time delay relay	
		115 Vac	5-1664
		230 Vac	5-1665
22	1	Light indicator	8750-106
23	1	Incandescent lamp	
		115 Vac	5-970-1
		230 Vac	5-970-2

SECTION V - REPLACEMENT PARTS LIST [CONT.]

<u>ITEM</u>	<u>QUANTITY</u>	<u>DESCRIPTION</u>	<u>PART NUMBER</u>
-------------	-----------------	--------------------	--------------------

Note - These items are part of the control assembly above.

24	1	Pipe nipple (flow switch)	5-489-1
25	1	Hex bushing (flow switch)	5-490-1

Accessory Connector Kits

26		Model 8775 Coupling Kit - 3-1/8" EIA	4600-020
		Consisting of:	
		Anchor bullet	4600-021
		O-Ring	4600-022
		Mounting hardware	4600-023
27		Model 8776 Coupling Kit - 3-1/8" Unflanged Flush - 50 ohm	5-726
